

SECTION A: BIOLOGY (34 marks)

Answer ALL the questions in this section in the spaces provided.

1 The diagram below represents the nitrogen cycle:

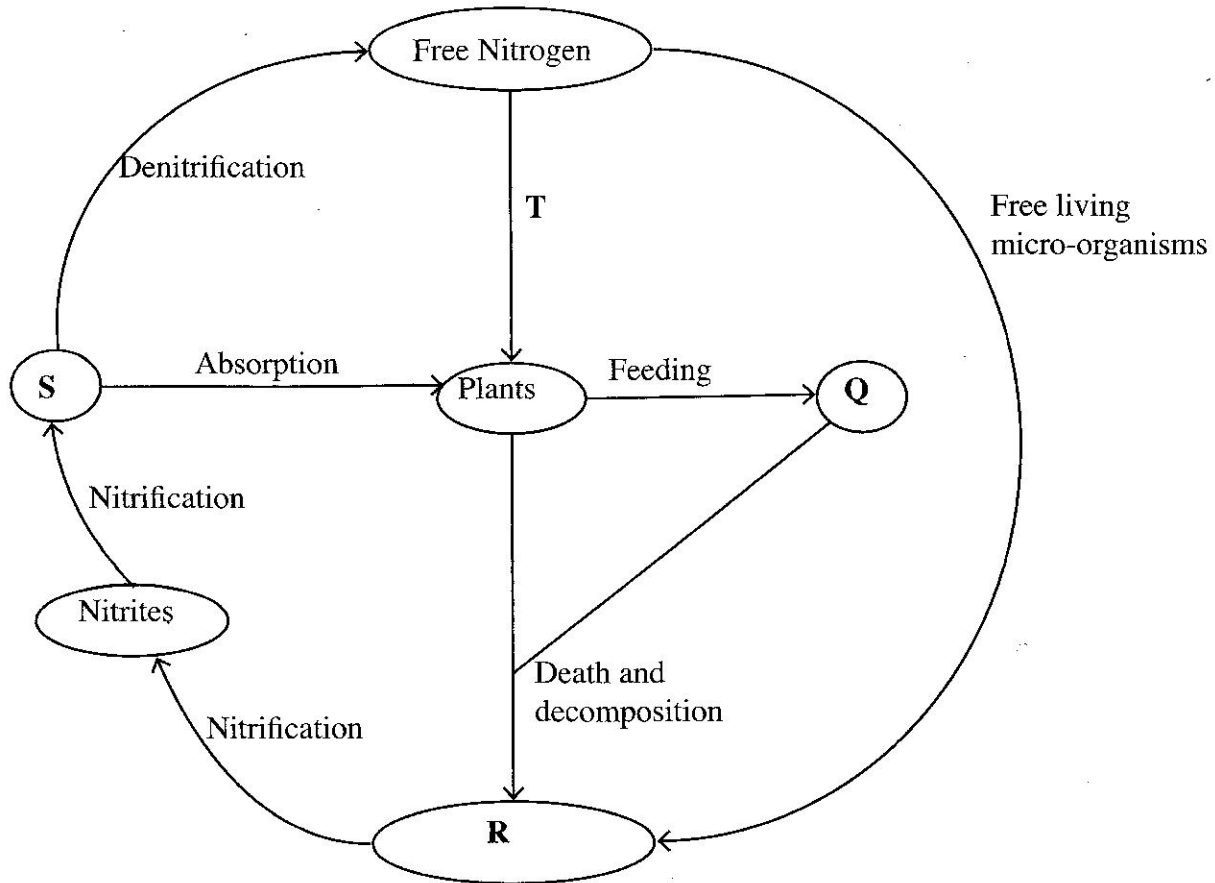

(a) Name the components labelled Q, R and S

Q

R

S

(3 marks)

(b) Name the process labelled T.

(1 mark)

(c) Give **one** example of organisms that cause decomposition.

(1 mark)

2 (a) State **one** function of each of the following structures in the human reproductive system:

(i) ovary;

(1 mark)

- (ii) epididymis. (1 mark)
- (b) What is gestation period? (1 mark)
- 3 (a) State the meaning of the following terms:
- (i) growth; (1 mark)
- (ii) development. (1 mark)
- (b) What is the importance of dormancy in seeds? (3 marks)
- 4 State **two** differences between continuous and discontinuous variations. (2 marks)
- 5 (a) (i) What is natural selection? (1 mark)
- (ii) Give **one** example of natural selection. (1 mark)
- (b) State **one** adaptation of *Ascaris lumbricoides* that enables them survive the digestive enzymes of their host. (1 mark)
- 6 The diagram below illustrates a certain tropic response.

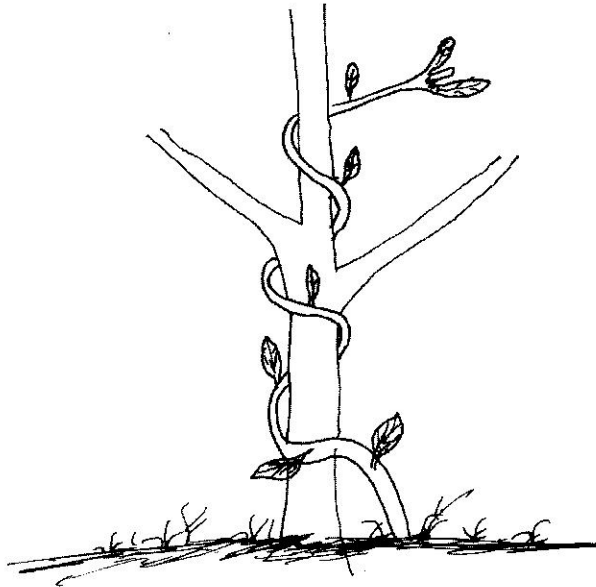

- (a) Name the tropic response illustrated in the diagram. (1 mark)
- (b) Give **two** survival values of the tropic response shown above to the plant. (2 marks)

7 The diagram below represents a neurone.

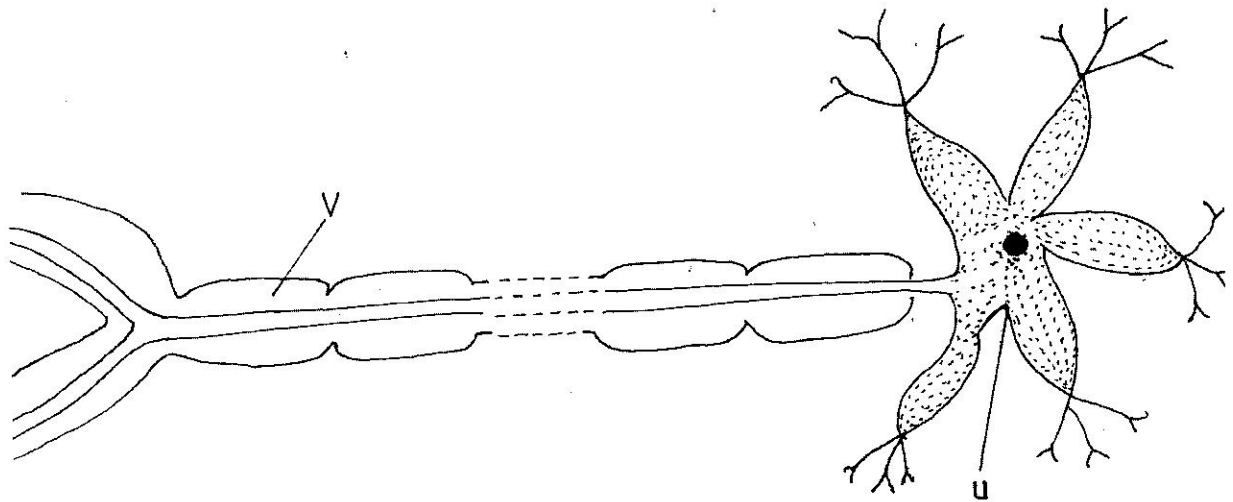

- (a) (i) Name the part labelled **V**. (1 mark)
- (ii) State **one** adaptation of the part labelled **U** to its function. (1 mark)
- (b) Name the part of the ear that is responsible for balancing. (1 mark)
- 8 (a) Name **two** types of movable joints in human beings. (2 marks)
- (b) State **one** function of the parenchyma tissue in young plants. (1 mark)
- 9 (a) What does the term implantation mean in human reproduction? (1 mark)
- (b) State **two** ways of reducing the spread of herpes simplex. (2 marks)
- 10 Why is the sex of a child determined by the father and not the mother? (4 marks)

SECTION B: CHEMISTRY (33 marks)

Answer ALL the questions in this section in the spaces provided.

- 11 The set-up shown below was used to investigate the rate of diffusion of ammonia and hydrogen chloride gases. Study it and answer the questions that follow.

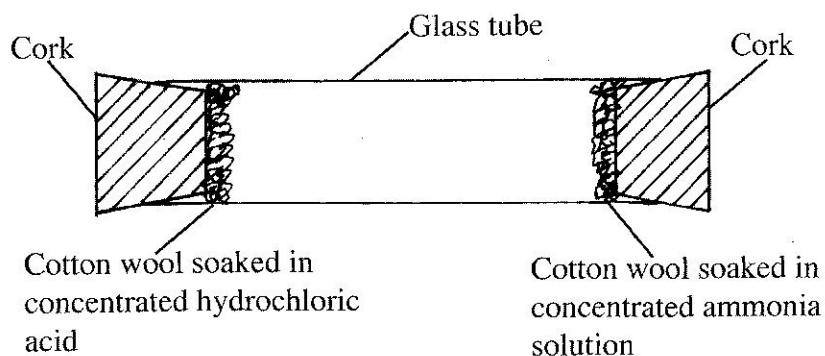

- (a) State the observation made in the glass tube. (1 mark)
- (b) (i) On the diagram, indicate with a cross (X) the likely position where the above observation is made. (1 mark)
- (ii) Explain your answer in b(i) above. (1 mark)
- 12 Calculate the mass that is contained in 0.1 moles of calcium carbonate. (Ca = 40.0; C = 12.0; O = 16.0). (2 marks)
- 13 In trying to investigate some properties of chlorine gas, a student introduced wet blue litmus paper into a gas jar containing the gas.

- (a) State the observations made in the gas jar. (1 mark)
- (b) Explain the observations in (a) above. (1 mark)

- 14 (a) (i) Name the compound whose structure is given below: (1 mark)

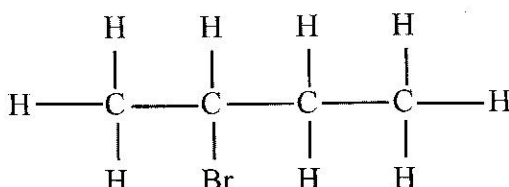

- (ii) Draw the structure of pent-2-ene. (1 mark)

- (b) Describe a chemical test that can be used to distinguish between butane and but-1-ene. (2 marks)

15 The set-up below was used to investigate some properties of ammonia gas. Study it and answer the questions that follow.

- (a) The clip was slightly opened to allow a drop of water to move up to the tip of the glass tube. After a few minutes, the clip was opened to allow more water to pass.

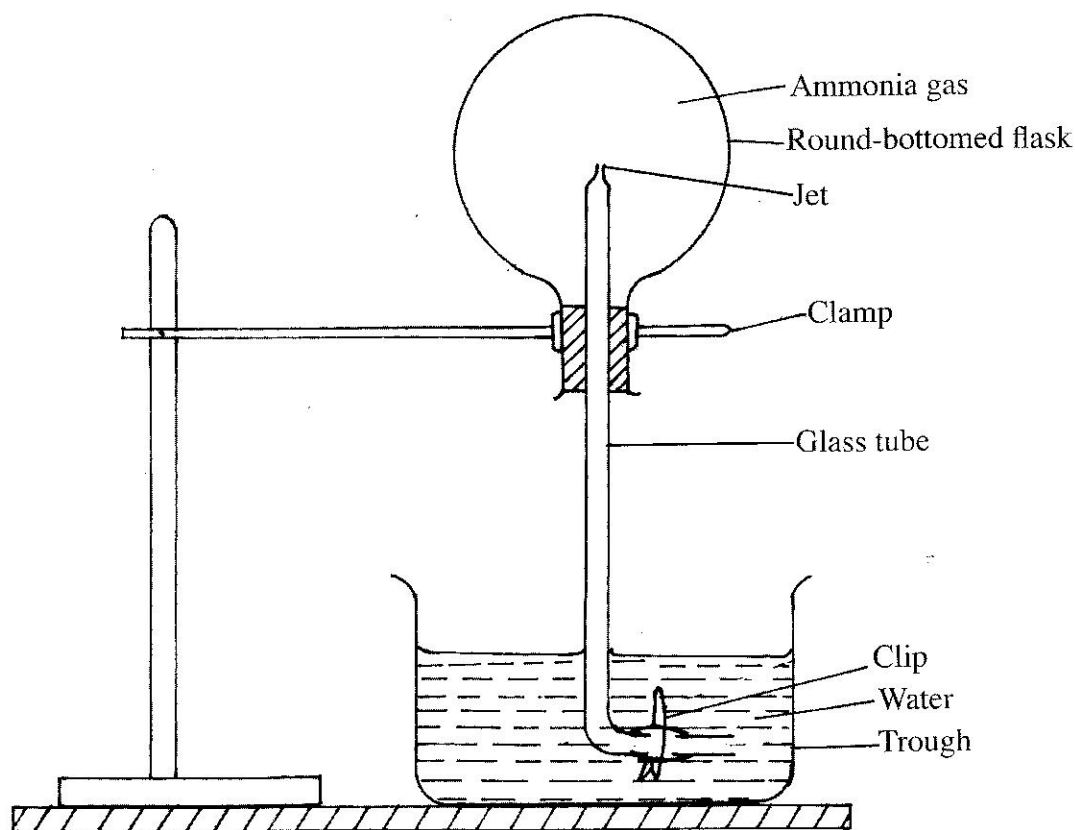

- (i) State the observation made in the round-bottomed flask. (½ mark)
- (ii) Explain the answer in a(i) above. (1½ marks)
- (b) Name **two** chemicals that can be used to prepare ammonia gas in a school laboratory. (1 mark)
- (c) Give **two** commercial uses of ammonia. (1 mark)
- 16 Sulphur (IV) oxide and oxygen react as shown in the equation below.



- (a) What is meant by $\Delta\text{H} = -\text{ve}$? (1 mark)

- (b) Explain the effect of increasing pressure on the position of equilibrium of the above reaction. (2 marks)
- (c) Give **one** use of sulphur (VI) oxide. (1 mark)
- 17 Charcoal and kerosene are some of the fuels commonly used in Kenyan homes.
- (a) What is meant by the term fuel? (1 mark)
- (b) Write a chemical equation for the complete combustion of charcoal. (1 mark)
- (c) Give **two** advantages of using kerosene as a fuel over charcoal. (2 marks)
- (d) Name **two** sources of energy in Kenya that are environmentally friendly. (1 mark)
- 18 142g of sodium sulphate were dissolved in 200 cm³ of distilled water. More water was added to make up to 500 cm³ of solution.
- (a) Calculate the molarity of the solution formed (Na = 23.0; S = 32.0; O = 16.0). (2 marks)
- (b) What volume of the solution is required to make a litre of solution of 0.5M. (2 marks)
- 19 (a) The raw materials used in the extraction of iron are iron ore, calcium carbonate, coke and air.
- (i) Write an equation for a reduction process in the blast furnace if the ore used was iron (III) oxide. (1 mark)
- (ii) What is the purpose of the calcium carbonate? (1 mark)
- (iii) Explain how the silica impurities are removed from the blast furnace. (2 marks)
- (b) Give **one** alloy that contains iron. (1 mark)

SECTION C: PHYSICS (33 marks)

Answer ALL the questions in this section in the spaces provided.

- 20 An object of height 24 cm is placed in front of a concave mirror. The magnification of the image is 0.5. Determine the height of the image. (3 marks)
- 21 It is observed that when a glass rod is brought near a positively charged sphere, repulsion occurs. State a reason for the repulsion. (1 mark)

22 Figure 1 represents a dry leclanché cell.

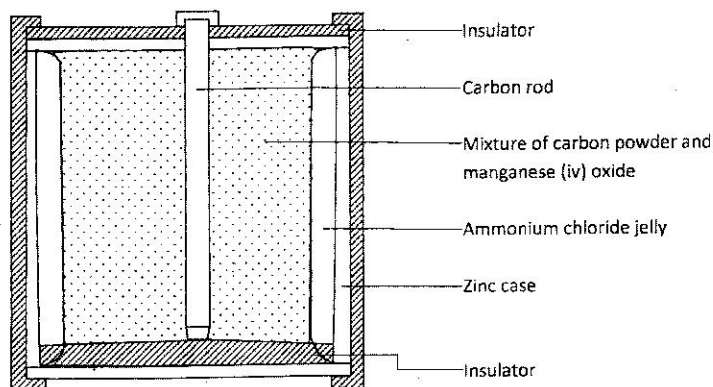

Figure 1

State the use of:

(a) carbon powder; (1 mark)

(b) manganese (IV) oxide. (1 mark)

23 In a laboratory there are two soft iron bars and two bar magnets. In the space provided draw a diagram to show how the two bar magnets and the soft iron bars can be arranged so that the strength of the magnet is maintained for a long time. (1 mark)

24 Figure 2 shows a block of wood floating in water.

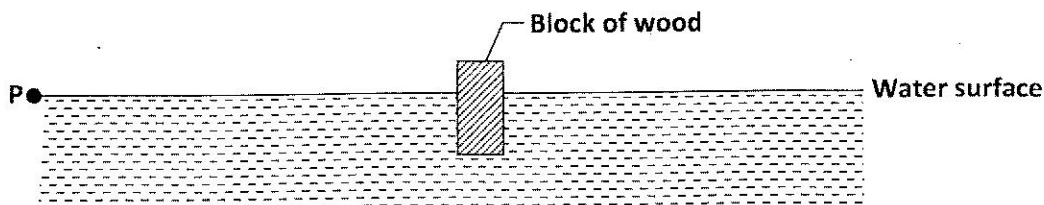

Figure 2

A wave is generated at point P. After some time the block of wood is seen to move up and down. State, with a reason the type of wave formed in the water. (2 marks)

- 25 **Figure 3** represents a set up that is used to study a property of sound. The pump in the set up is used to remove air from the jar.

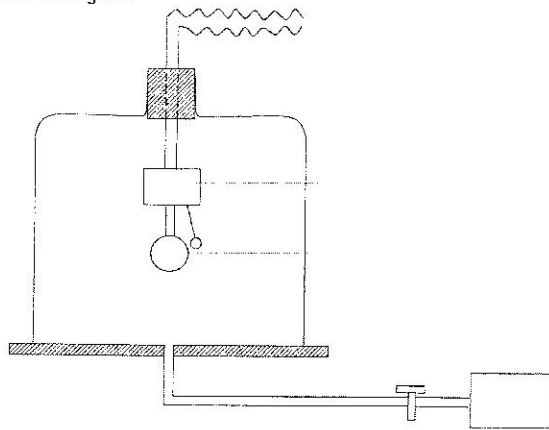

Figure 3

As the air was being removed from the jar the loudness of the sound of the bell decreased until the sound could no longer be heard. Explain why the sound could no longer be heard although the bell continued working. (2 marks)

- 26 (a) **Figure 4** shows a battery whose potential difference is 3 V connected in series with resistors R_1 and R_2 . A voltmeter V is connected across R_2 .

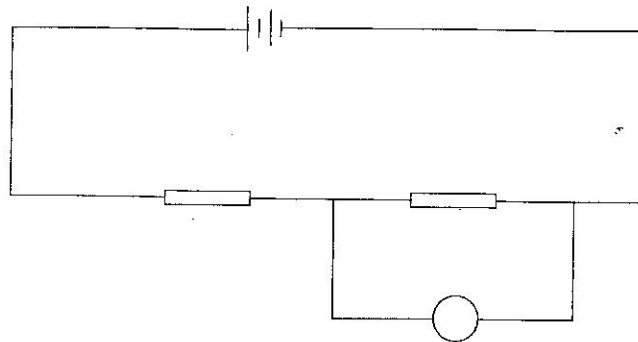

Figure 4

The potential difference across R_1 is 2 V. Determine the reading of the voltmeter, V .

(1 mark)

- (b) **Figure 5** shows part of a circuit containing three resistors R_3 , R_4 and R_5 and an ammeter. A current of 0.4 A is flowing through R_3 and a current of 0.1 A is flowing through R_4 .

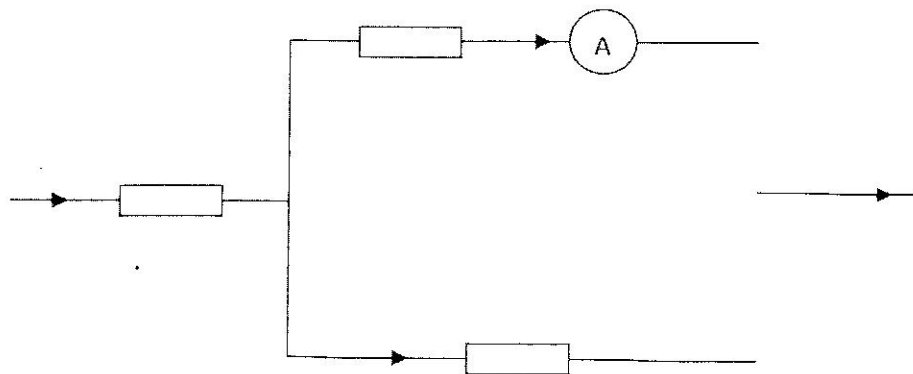

Figure 5

Determine the reading on the ammeter.

(1 mark)

- 27 **Figure 6** shows a circuit in which a coil of wire is connected in series with a variable resistor, a battery and a switch.

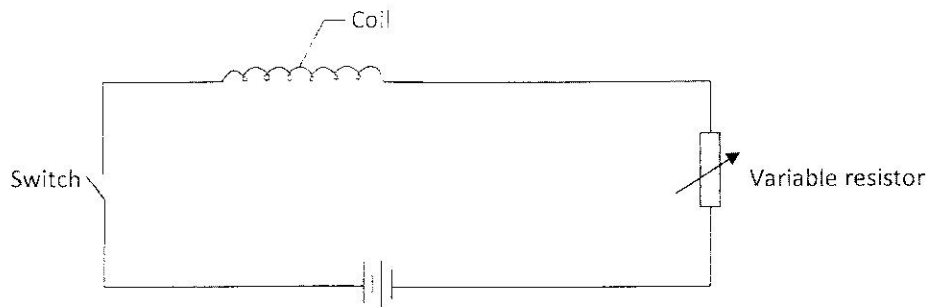

Figure 6

The coil gets heated when the switch is put on. The resistance in the circuit is then reduced using the variable resistor. State, with a reason the effect on the heat produced in the coil.

(2 marks)

- 28 **Figure 7** shows a ray of light in air incident to a rectangular glass block.

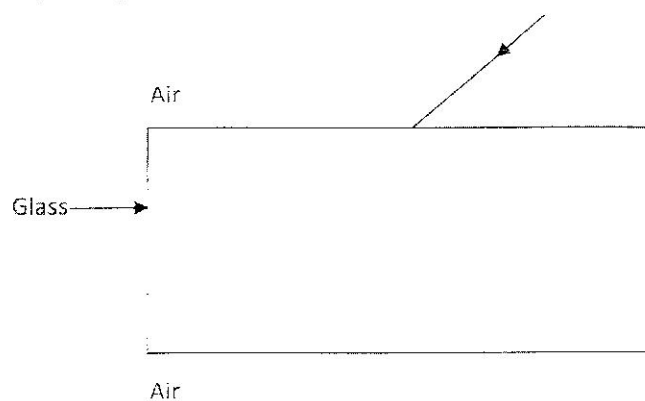

Figure 7

Complete the diagram to show the path of the ray as it passes through the glass into the air.

(2 marks)

- 29 **Figure 8** shows an object O in front of a diverging lens. The principal focus of the lens is marked F.

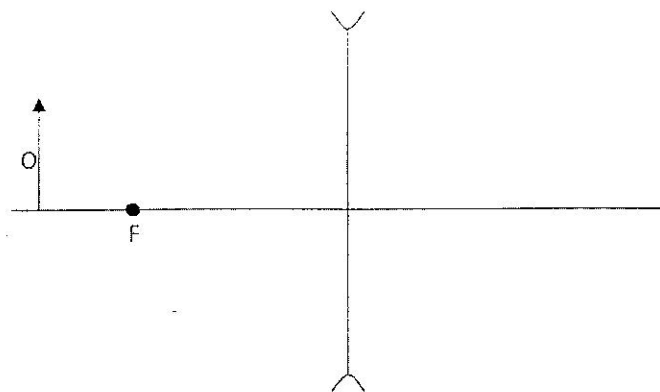

Figure 8

On the figure, draw a ray diagram to locate the image. (3 marks)

30 Figure 9 shows a graph of amplitude against time for a wave.

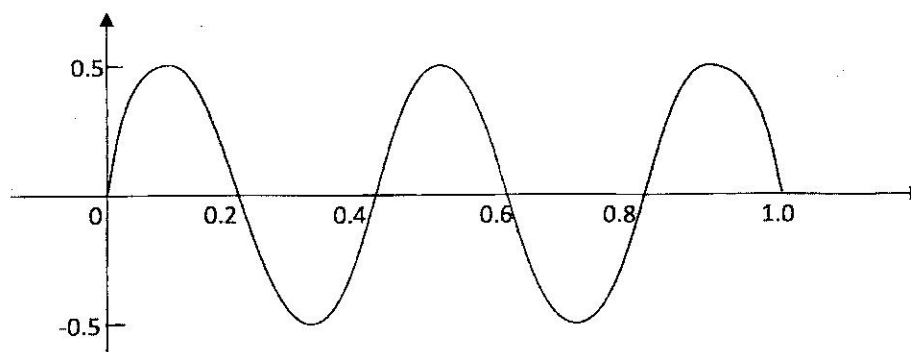

Figure 9

Using the figure, determine the period of the wave. (1 mark)

31 (a) Explain why the voltage of the mains electricity from a generating station is stepped up before the electricity is transmitted over long distances. (2 marks)

(b) State why a fuse should be connected to the live wire in a domestic wiring circuit. (1 mark)

32 Figure 10 shows a simplified cathode ray tube.

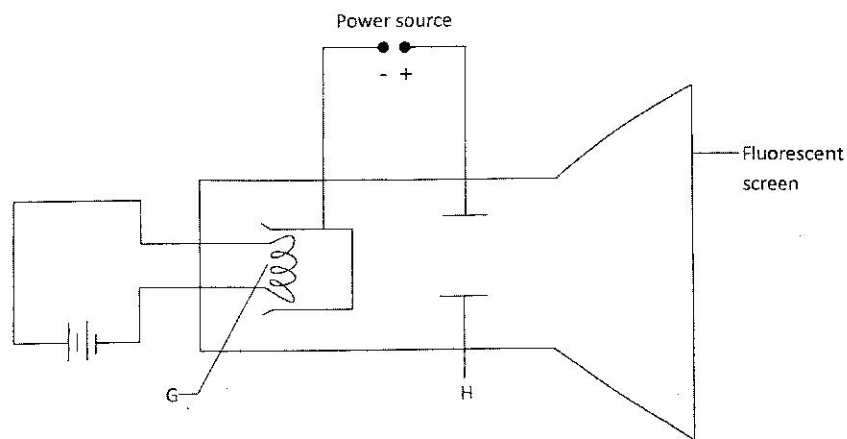

Figure 10

(a) Name the part labelled H. (1 mark)

(b) State the purpose of the part labelled G. (1 mark)

(c) State how the cathode rays affect the screen. (1 mark)

- 33 (a) An X-ray tube produces x-rays of low penetrating power. State the adjustment that should be made to the circuit connected to the tube so that the X-rays produced are of a higher penetrating power. (1 mark)
- (b) State a reason why X-rays are not deflected when they pass through an electric field. (1 mark)

- 34 **Figure 11** shows an instrument which is used to detect radioactive emissions. The metal tube contains an inert gas at low pressure.

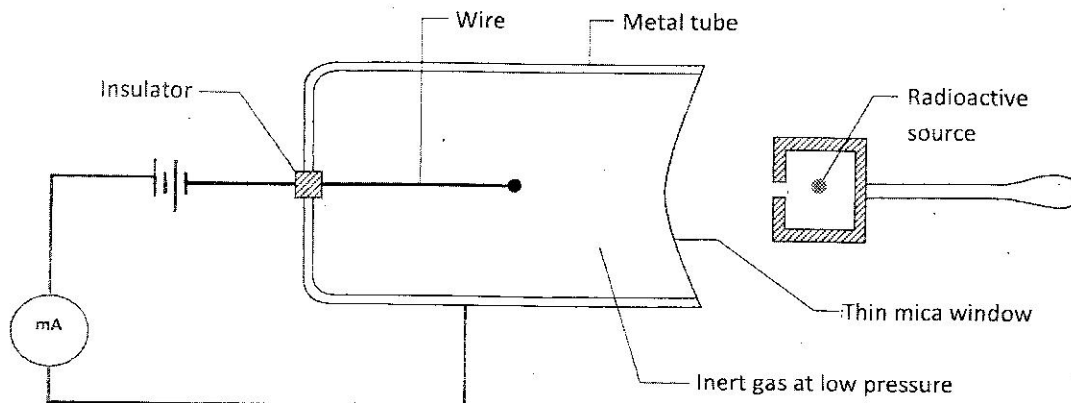

Figure 11

When the radioactive source is brought close to the mica window the milliammeter is observed to deflect repeatedly. Explain this observation. (2 marks)

- 35 Explain how an n-type semi conductor can be produced from silicon. (2 marks)